

**Modular Cooking Range Line  
 thermaline 85 - 4 Zone Electric Solid Top  
 on Warming Cabinet, 1 Side with  
 Backsplash (H2) H=700**

ITEM # \_\_\_\_\_

MODEL # \_\_\_\_\_

NAME # \_\_\_\_\_

SIS # \_\_\_\_\_

AIA # \_\_\_\_\_



**588704 (MBLPGBH4AO)** Electric Solid Top, 4 zones, one-side operated, on Warming Cabinet - H2

### Short Form Specification

**Item No.** \_\_\_\_\_

Unit constructed according to DIN 18860\_2 with 20 mm drop nose top. Internal frame for heavy duty sturdiness in stainless steel. 2 mm top in 1.4301 (AISI 304). Flat surface construction, wide rounded, easily cleanable. THERMODUL connection system enables seamless worktop when units are connected and avoids soil penetrating. Solid top made of smooth, pore-free, steel. 4 independently controlled heating zones with 2 electronic sensors per zone for temperature surface control and 8 power levels. Rapid plate heat up, continuously ready to use. Overheat protection switches off the supply in case of overheating. Standby function saves energy and quickly recovers maximum power. Metal knobs with embedded hygienic silicon "soft" grip enable easier handling and cleaning. 800 mm wide warming cabinet with 2 doors, constructed according to DIN 18860\_2 with 70 mm recessed plinth. Internal frame for heavy duty sturdiness in stainless steel. 2 mm top in 1.4301 (AISI 304). Flat surface construction, easily cleanable. THERMODUL connection system enables seamless worktop when units are connected and avoids soil penetrating. Temperature in the cabinet can be set through thermostat, up to a maximum of 110 °C. Cabinet storage space accepts GN 1/1 containers. IPX5 water resistant certification.

### Main Features

- 4 heating zones independently controlled.
- Rapid heat up of the plate and continuously ready for use.
- Overheat protection: the temperature sensor switches off the supply in case of overheating.
- Pans can easily be moved from one area to another without lifting.
- Wide rounded cleaning zone around the plates for easier cleaning.
- All major components may be easily accessed from the front.
- THERMODUL connection system creates a seamless work top when units are connected to each other thus avoiding soil penetrating vital components and facilitating the removal of units in case of replacement or service.
- Metal knobs with embedded hygienic "soft-touch" grip for easier handling and cleaning. The special design of the controls prevents infiltration of liquids or soil into vital components.
- Cooking plate and base joint profile guarantee against soil infiltration.
- Two electronic sensors per zone to control surface temperature and to protect cooking plate from overheating.
- 8 power levels.
- Unit constructed according to DIN 18860\_2 with 70 mm recessed plinth.
- Temperature in the cupboard can be set through a thermostat to suit different requirements. The maximum temperature is 110°C.
- Solid top cooking surface made of 20 mm thick steel, DIN 1.7335, smooth pore-free and easy to clean.

### Construction

- 2 mm top in 1.4301 (AISI 304).
- Flat surface construction with minimal hidden areas to easily clean all surfaces
- Unit constructed according to DIN 18860\_2 with 20 mm drop nose top.
- Storage space in the base of the appliance accepts GN1/1 containers.
- IPX5 water resistance certification.
- Internal frame for heavy duty sturdiness in stainless steel.

### Sustainability

- Standby function for energy saving and fast recovery of maximum power.

### Optional Accessories

- Connecting rail kit for appliances PNC 912498  with backsplash, 850mm
- Portioning shelf, 800mm width PNC 912526
- Portioning shelf, 800mm width PNC 912556
- Folding shelf, 300x850mm PNC 912579
- Folding shelf, 400x850mm PNC 912580

**APPROVAL:** \_\_\_\_\_

- Fixed side shelf, 200x850mm PNC 912586
- Fixed side shelf, 300x850mm PNC 912587
- Fixed side shelf, 400x850mm PNC 912588
- Stainless steel front kicking strip, 800mm width PNC 912634
- Stainless steel side kicking strip left and right, wall mounted, 850mm width PNC 912659
- Stainless steel side kicking strip left and right, back-to-back, 1700mm width PNC 912662
- Stainless steel plinth, against wall, 800mm width PNC 912882
- Stainless steel side panel, 850x700mm, right side, against wall PNC 913003
- Stainless steel side panel, 850x700mm, left side, against wall PNC 913004
- Back panel, 800x700mm, for units with backsplash PNC 913013
- Endrail kit, flush-fitting, with backsplash, left PNC 913115
- Endrail kit, flush-fitting, with backsplash, right PNC 913116
- Endrail kit (12.5mm) for thermaline 85 units with backsplash, left PNC 913206
- Endrail kit (12.5mm) for thermaline 85 units with backsplash, right PNC 913207
- U-clamping rail for back-to-back installations with backsplash (to be ordered as S-code) PNC 913226
- Insert profile, d=850mm PNC 913231
- Perforated shelf for warming cabinets and cupboard bases (one-side operated TL80-85-90 and two-side operated for TL80) PNC 913234
- Energy optimizer kit 32A - factory fitted PNC 913247
- Side reinforced panel only in combination with side shelf, for against the wall installations, right PNC 913261
- Side reinforced panel only in combination with side shelf, for against the wall installations, left PNC 913262
- Shelf fixation for TL80-85-90 one-side operated, TL80 two-side operated PNC 913281
- Filter W=800mm PNC 913665
- Stainless steel dividing panel, 850x700mm, (it should only be used between Electrolux Professional thermaline Modular 85 and thermaline C85) PNC 913670
- Stainless steel side panel, 850x700mm, flush-fitting (it should only be used against the wall, against a niche and in between Electrolux Professional thermaline and ProThermetic appliances and external appliances - provided that these have at least the same dimensions) PNC 913686

Front

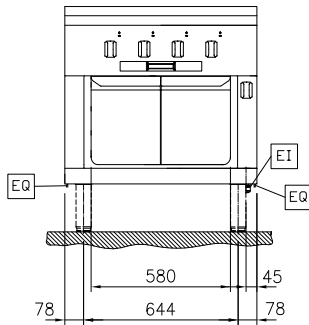

Side

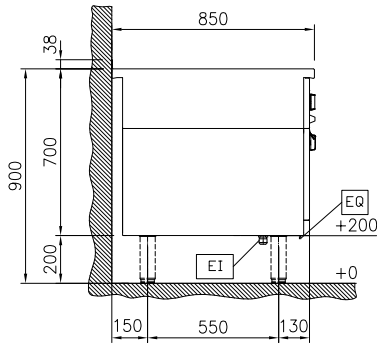

EI = Electrical inlet (power)  
 EQ = Equipotential screw

Top

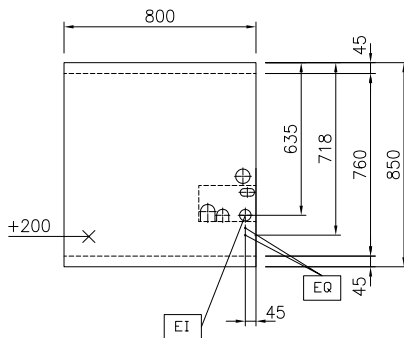

### Electric

Supply voltage: 400 V/3N ph/50/60 Hz  
 Electrical power, max: 14.3 kW

### Key Information:

Working Temperature MIN: 100 °C  
 Working Temperature MAX: 450 °C  
 External dimensions, Width: 800 mm  
 External dimensions, Depth: 850 mm  
 External dimensions, Height: 700 mm  
 Net weight: 149 kg  
 Configuration: On Oven; One-Side Operated  
 Front Plates Power: 3 - 3 kW  
 Back Plates Power: 3 - 3 kW  
 Solid top usable surface (width): 670 mm  
 Solid top usable surface (depth): 650 mm

### Sustainability

Current consumption: 30.5 Amps